

STANDARD OPTIONS		
WIDTH	HEIGHT	# OF RAILS
8' NOM	4' - 10'	2 - 4

**BETA FENCE**  
 MANUFACTURED BY PAYNE USA  
 Main: 972-878-7000 Fax: 972-878-4703  
 3309 S. I-45 ENNIS, TX 75119  
 www.BetafenceUSA.com

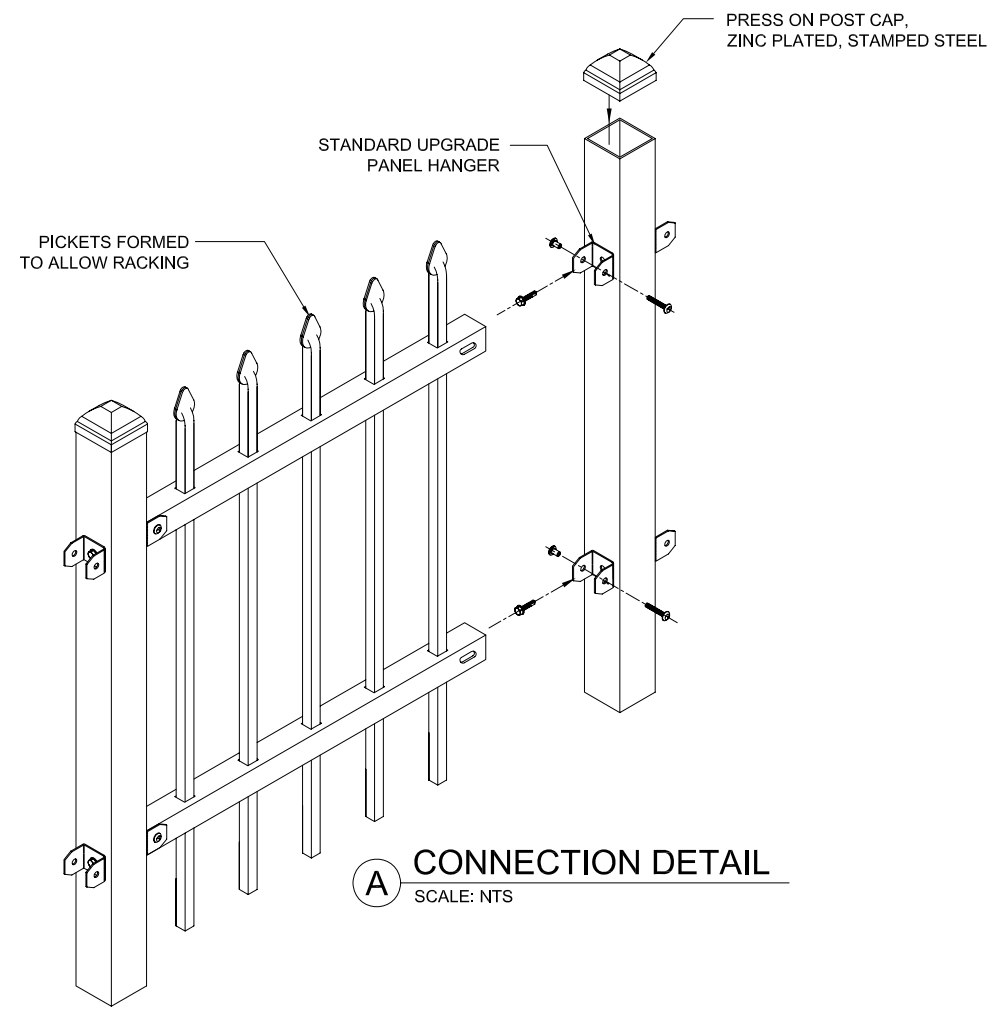

**A CONNECTION DETAIL**  
 SCALE: NTS

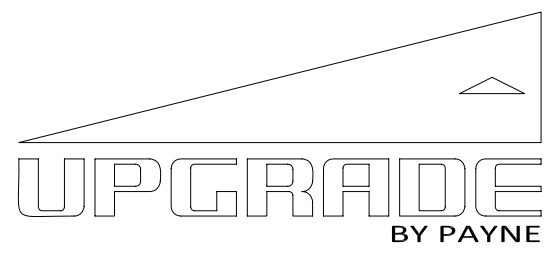

GALVANIZED STEEL TUBING  
 POWDER COAT: SEMI-GLOSS BLACK (STD.)

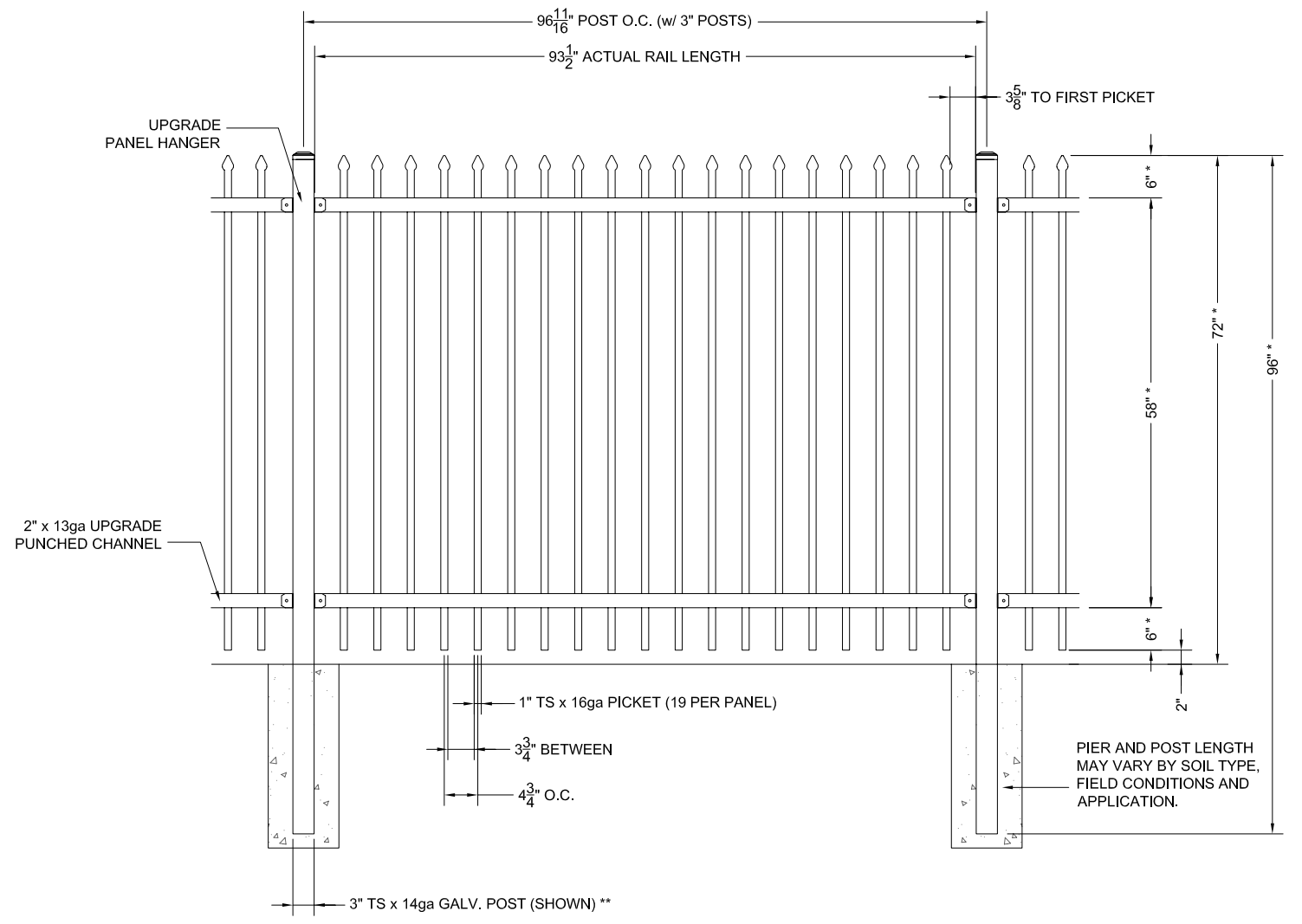

**1 TYPICAL ELEVATION**  
 SCALE: NTS

PICKET OPTIONS			FINIAL OPTIONS			
SUMMIT	PINNACLE	LANDMARK	LANCE	CROWN	FLAIR	FANFARE

NOTES:  
 \* DIMENSIONS VARY WITH PANEL HEIGHT AND NUMBER OF RAILS  
 \*\* PLEASE SEE SPECIFICATION FOR ADDITIONAL POST SIZES AND SPACING

**UPGRADE - 1 SG PANEL INDUSTRIAL GRADE**

PROJECT NAME:	XXXXXXXXXXXX	SALES ORDER:	SOXXXX
CUSTOMER:	XXXXXXXXXXXX	STORE #:	XXXXXXXXXXXX

VIEW:	XXXX	
SCALE:	NTS	
DRAWN BY:	XXXX	
CHECKED BY:	XXXX	
APPROVED BY:	XXXX	
DATE:	XX-XX-XX	
FILE:	UPGRADE.dwg	
REV	DATE	DRAFTER
1	26-SEP-09	RWN
2	15-FEB-10	CAR
3	22-MAR-10	CAR
4	09-APR-10	JGS
5	13-APR-10	JGS

**SHEET 1**